



4JH Series - 80 / 110

Configuration	In-line, 4-stroke, vertical, water-cooled diesel engine	
Max. output at crankshaft*	58.8 kW@3000 rpm	[80 mhp@3000 rpm]
	80.9 kW@3000 rpm	[110 mhp@3000 rpm]
No. of cylinders	4 cylinder	
Displacement	2.000 L	[1.22 cu in]
Bore x stroke	84 mm x 90 mm	[3.31 in x 3.54 in]
Aspiration	Turbocharged & intercooled	
Combustion system	Direct injection, Bosch common rail system	
Starting system	Electric starting 12V - 1.4 kW	
Engine management	Electronic	
Cooling system	Fresh water cooling by centrifugal fresh water pump	
	Seawater cooling by rubber impeller seawater pump	
Alternator	12V - 125A	
Lubrication system	Enclosed, forced lubricating system	
Engine lube oil specifications	API class: CD or higher, SAE grade: 10W-30 or 15W-40	
Direction of rotation at crankshaft	Counterclockwise (CCW) viewed from stern	
Dry weight without gear	229 kg	[505 lbs]
Engine dimensions† L x W x H	909 x 613 x 675 mm	
Emission compliance	EU: RCD 2, BSO II, EMC	US: EPA Tier 3, EPA-C
Flywheel housing size	SAE #4	
Controls	Mechanical (optional - VC20 system)	

NOTE: Fuel condition: Density at 15°C = 0.84 g/cm³: 1 kW = 1.3596 mhp = 1.3410 HP

Technical data is according to (ISO 8665) / (ISO 3046)

* Fuel temperature 40°C at the inlet of the fuel injection pump [ISO 8665: 2006]

†Length includes KM4A2 marine gear (Dimensions may vary with other gears, drives or elbow)

DIMENSIONS

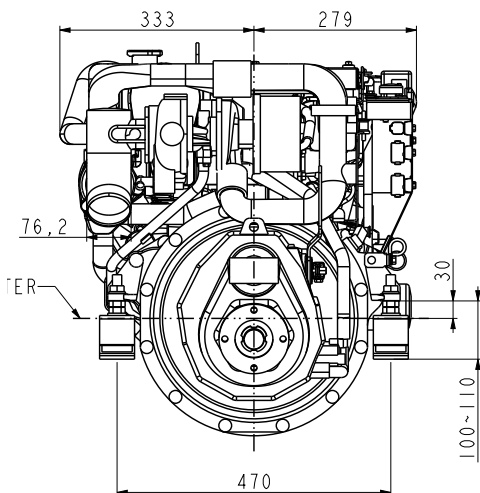
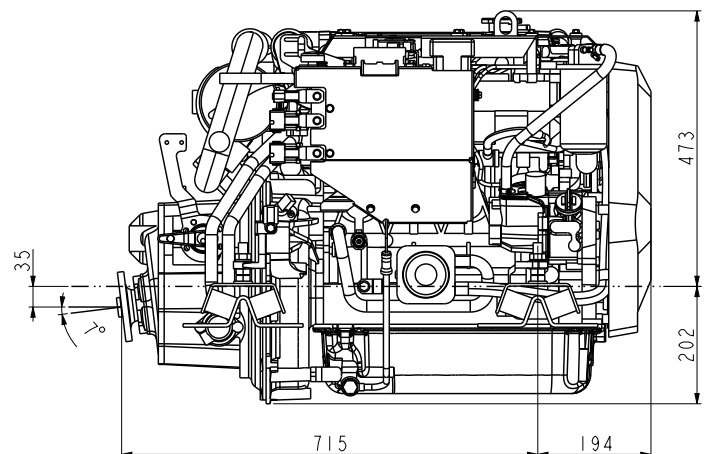
Rear view**Right side view**

4JH80/110 with KM4A2 marine gear
(Not to be used for engine installation)



PERFORMANCE CURVES

4JH80 Torque curve

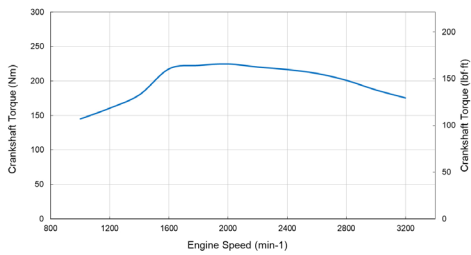

4JH80 Output Power curve

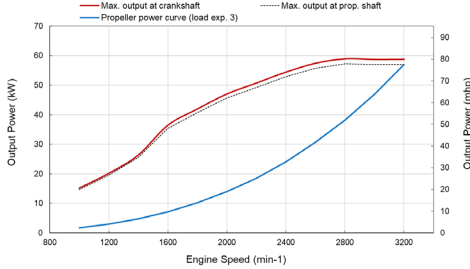

4JH80 Fuel consumption (proload exp 3.0)

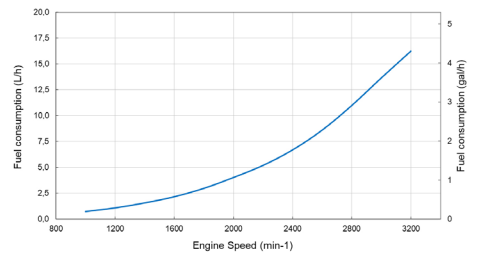

4JH110 Torque curve

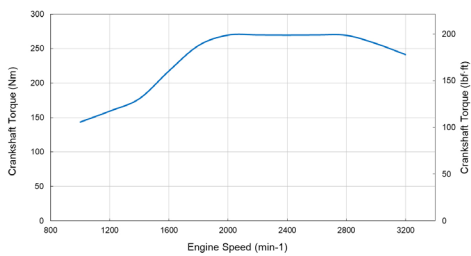

4JH110 Output Power curve

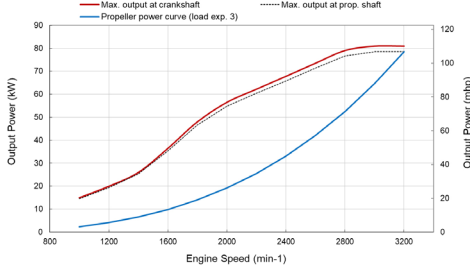

4JH110 Fuel consumption (proload exp 3.0)

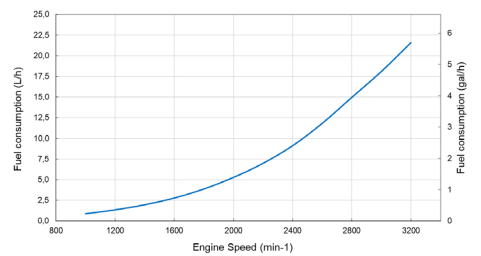

MARINE GEAR / DRIVE*

Model	KMH4A [down angle: 8°]	KM4A2 [down angle: 7°]	ZF25A [down angle: 8°]	ZF30M [paralle]	Saildrive [SD60]**
Clutch type	Hydraulic multi disc	Mechanical cone clutch	Hydraulic multi disc	Mechanical multi-disc	Mechanical multi-disc
Dry weight	30 kg [66 lbs]	28.5 kg [63 lbs]	33 kg [73 lbs]	28 kg [62 lbs]	44 kg [97 lbs]
Reduction ratio [fwd/asn]	2.04/2.04 2.45/2.45	1.47/1.47 2.14/2.14 2.63/2.63	1.93/1.93 2.80/2.80	2.15/2.64 2.70/2.64	2.23/2.23 2.49/2.49
Direction of rotation [viewed from stern]	Clockwise & counterclockwise		Clockwise & counter-clockwise	Clockwise	Clockwise & counter-clockwise
Lubrication system	Forced lubrication	Splash lubrication	Forced lubrication	Splash lubrication	Splash lubrication
Lube oil specifications	API class: CD or higher, SAE grade: #20 or #30		ATF	ATF	API class: CD or higher, SAE grade: 15W-40
Max. lube oil capacity	2.0 L	2.0 L	1.8 L	1.1 L	2.8 L
Dry weight - engine & gear	259 kg [571 lbs]	257.5 kg [568 lbs]	262 kg [578 lbs]	257 kg [567 lbs]	273 kg [602 lbs]

* Other marine gearboxes and configurations available upon request. Contact your local supplier for more information.
 ** Not for 4JH110

ACCESSORIES

Standard engine package

- Exhaust mixing elbow [L-type]
- Alternator 12V - 125A
- Seawater pump rear mounted
- B25 panel
- Flexible mounts
- Mechanical throttle sensor
- Fuel pre-filter with water separator
- Fresh water expansion tank
- Belt safety cover

Optional

- High-riser mixing elbow [instead of L-elbow]
- Secondary alternator 12V - 125A or 24V - 60A
- Seawater pump front mounted
- C35 panel
- Extension harness [3m, 5m, 10m]
- Second station
- Sidemount control head
- VC20 Vessel Control System

- NMEA2000 Engine monitoring system
- Semi 2-pole
- SOLAS including Certificate [factory fit only]
- Opposite dipstick
- Hot water kit with cocks
- Extension saildrive leg [75 mm]
- Propeller cone nut kit SD60
- On-board spare parts kit

NOTE: All data subject to change without notice. Text and illustrations are not binding.